

SWAN Air Cooled Piston Compressor

天鵝牌空氣壓縮機



Brand You Know
Performance You Trust

優質、專業、新活力



SWAN Air Cooled Piston Compressors

天鵝牌空氣壓縮機



Patented easy access drain mechanism mounted on top of the air tank for easy periodical maintenance.

獨家專利桶上洩水，方便洩除桶內的冷凝水。

Smart controller. Suitable for all industrial users.

智慧型全自動控制操作簡單，更適合各行各業的作業條件。



Special Features For SVU(P)-215/220

SVU(P)-215/220獨家專利與特點



Guide plate for cooling air flow ensures better cooling effects!

設置冷卻氣流的導風板增加壓縮熱源冷卻效果大幅降低壓縮熱的溫度

Low oil pressure protection
失油保護開關



New breather design and unique oil mist collection mechanism ensure the lowest oil consumption!

獨特的加油通氣管設計
潤滑油份回收設計
確保冷凝油不噴溢
減少潤滑油的損失
兼顧綠色環保境界

Special oil return pipe design to reduce possible oil splashing!

潤滑油回油特殊設計
減少內部潤滑油飛濺
降低壓縮空氣含油量

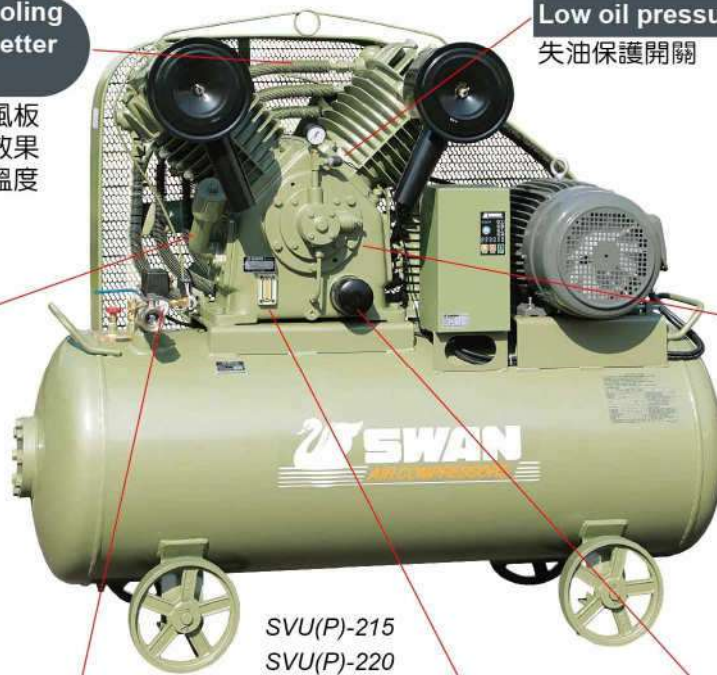

SVU(P)-215
SVU(P)-220



Solenoid Valve
電磁閥



Oil Gauge
油鏡



Oil Filter
油過濾器

Model 型式	Specs. 規格		Motor (kw/hp) 馬達	Working Pressure (kg/cm ² .g) 使用壓力	Speed (r.p.m) 轉速	F.A.D. (l/min) 實際排氣量	Tank Capacity (liter) 儲氣桶容量	Compressor Blocks Physical Dimensions 機體實體尺寸		Compressor Units Physical Dimensions 整台實體尺寸	
	LxWxH(mm)	重量(kg)						LxWxH(mm)	重量(kg)		
SVU(P)-215	11	15	8	550	1520	400	910x760x860	265	1820x730x1480	560	
SVU(P)-220	15	20	8	710	2000	400	910x760x860	265	1820x730x1480	560	

※Keep on developing for excellence, we reserve the right to alter specifications without prior notice.

※Other special air discharge quantity, pressure and drive type are available upon request.

※本公司不斷研究改進，規格如有變更，恕不另行通知。

※規格外之壓力、排氣量、空壓設備，詳細資料歡迎與本公司洽詢。

S Series

S系列 氣冷移動式

S Series

Unique Components and Mechanism

獨特配件與功能



Highly efficient and durable valve assemblies are provided through the use of special material treatments and high precision grinding processes

經熱處理及精密研磨的進排氣閥組，注意每環節確保效率與壽命。



SWU(P)-415



Product quality guaranteed through the application of modern technology such as CAD/CAM that is used in all functions from product development, modeling and design, right through to the manufacturing process.

以CAD/CAM進行分析、模擬、設計、製造、品質的發展從設計開始。



High quality and consistent components are manufactured through machining centers which typically are capable of completing a finished surface in a single set-up.

以大型自動加工中心機進行精密加工，一次夾持完成各加工面，確保精度的一致性。



Compressor Pump Only

壓縮機機體



SWU-310



HVU-205

All metal surfaces on compressor units are prepared by initially shot blasting, followed by the application of powder coating to ensure bright, durable and environmentally friendly air tank surface protection.

鋼珠噴砂處理，自動粉體塗裝；注重環保並確保外觀晶亮耐久。

Model 型式	Specs. 規格		Working Pressure (kg/cm ² .g) 使用壓力	Speed (r.p.m) 轉速	F.A.D. (l/min) 實際排氣量	Tank Capacity (liter) 儲氣桶容量	Compressor Blocks Physical Dimensions 機體實體尺寸		Compressor Units Physical Dimensions 整台實體尺寸	
	馬	達					LxWxH(mm)	重量(kg)	LxWxH(mm)	重量(kg)
SP-114	0.2	1/4	8	675	36	36	160x200x250	6.2	775x290x605	26
SVP-212	0.4	1/2		700	76	58	335x265x265	14.6	940x330x700	52
SVU(P)-201	0.75	1		1020	140	85	380x280x340	21	1000x440x780	58
SVU(P)-202	1.5	2		880	225	85	410x290x350	25	1000x440x780	62
SVU(P)-203	2.2	3		650	355	106	540x400x450	51	1350x450x840	110
SVU(P)-205	3.7	5		620	545	155	560x400x450	70	1400x520x980	168
SWU(P)-307	5.5	7.5		850	872	240	650x460x550	93	1470x650x1150	230
SWU(P)-310	7.5	10		850	1151	300	700x460x560	95	1835x650x1200	250
SWU(P)-415	11	15		850	1480	300	700x520x550	118	1835x650x1200	275

H Series

H系列 氣冷移動式

Insist on the best and prestige comes from 60 years' experience and persistence.

一甲子專業經驗與最佳品質



HWU(P)-415



HWP-310

Model Selection

- Define the predicted air volume requirement, plus 30% additional to select for an appropriate compressor model.
- Consider any predictable increase in air volume demand, such as increasing automatic equipment in the future.
- The correct selection will minimize capital and power consumption costs.

機型選擇

- 確認需要風量並選擇至少有30%餘裕之機型。
- 請考慮將來自動化設備增加，壓縮空氣使用量增多的情況，並預作規劃。
- 機型選擇正確與否影響購置成本及電費。

Control System Selection

- **Automatic Unloader System "U" Type**
Through automatic unloading system allows for the control of loaded and unloaded compressor status through a range of pre-set pressure values. This system is recommended where the duty cycle exceeds 50%, and for all larger compressors units.
- **Pressure Switch System. "P" Type**
The automatic pressure switch will stop and start the compressor according to air demand. It is normally recommended for intermittent operation and smaller compressor units.
- **U Type & P Type Interchangeable System**
The integration of pressure switch, solenoid valve and smart IC controller allows air compressor to switch U type system and P type system automatically according to the air volume requirement, ensuring best efficiency. (※For SVU(P)-215, SVU(P)-220, SWU(P)-415, HVU(P)-215 and HWU(P)-415 only.)
- **The correct selection will extend compressor's service life and reduce power consumption.**

型式選擇

- **U型**：用自動釋荷閥控制空壓機的空車、重車；適用於較大馬力機型及連續運轉型。
- **P型**：用壓力開關控制空壓機的停車及再啟動；適用於較小馬力機型及間續使用型。
- **U&P共用型**：用壓力開關與電磁閥，結合智慧型IC控制器。空壓機可依照氣源需求量自動調節全、半自動，最佳運轉效能。
(※使用機型SVU(P)-215、SVU(P)-220、SWU(P)-415、HVU(P)-215、HWU(P)-415。)
- 型式選擇正確與否影響空壓機使用壽命及電費。

Model 型式	Specs. 規格		Working Pressure (kg/cm ² .g) 使用壓力	Speed (r.p.m) 轉速	F.A.D. (l/min) 實際排氣量	Tank Capacity (liter) 儲氣桶容量	Compressor Blocks Physical Dimensions 機體實體尺寸		Compressor Units Physical Dimensions 整台實體尺寸	
	馬	達					LxWxH(mm)	重量(kg)	LxWxH(mm)	重量(kg)
HVU(P)-203	2.2	3	16	960	270	237	500x330x400	47	1470x550x1100	205
HVU(P)-205	3.7	5		900	406	237	560x380x460	67	1470x550x1100	225
HWU(P)-307	5.5	7.5		850	606	237	620x480x540	93	1470x640x1150	260
HWU(P)-310	7.5	10	12	850	786	237	650x480x540	95	1470x640x1150	262
HWU(P)-415	11	15		850	1120	300	1835x650x1150	116	730x550x660	361
HVU(P)-215	11	15		710	1064	300	930x650x690	280	2230x800x1400	515

Smart Controller

智慧型面板



復歸鍵 停止鍵 啟動鍵

Power Indicator 電源指示燈
Stop Indicator 停止指示燈
Start Indicator 運轉指示燈
Stand-by Indicator 備機指示燈

Overload Indicator
O.L 電流過負載指示燈
Low oil Pressure Indicator
A.1 失油保護指示燈
Remote-control Indicator
R/L 遠端操作指示燈

- The distinctive and high efficient design enable to eliminate wearing damages to all mechanical parts during ON/OFF and loading / unloading operations. 特殊的設計，在空車啟動與空車停機時降低磨擦阻力對機械的傷害。
- The user friendly control system can monitor exactly the running conditions of the remote compressors. 本機、遠端彈性化操控，選擇更人性化。
- Intelligent control system is able to self-adjust to execute automatic or semi-automatic control mode. 智慧型自動控制，可自動調節為全自動或半自動操作模式。
- Multiple protective system and intimate design to completely meet customers' requirements. 貼心設計，多重保護控制系統功能。
- Simple and visible indicator lights. 操控面板指示燈顯示運轉狀態。

Compressed Air Cleaning System

空氣清淨化系統

Features

- Comprehensive range of filters to meet requirements from different industrial users.
- We supply different grade of air filtrating systems to meet various applications.

特點

- 配合不同工業用戶需求，提供各種樣式過濾器組合。
- 因應客戶不同的用途，不同的清淨化需求，提供不同等級的過濾系統。

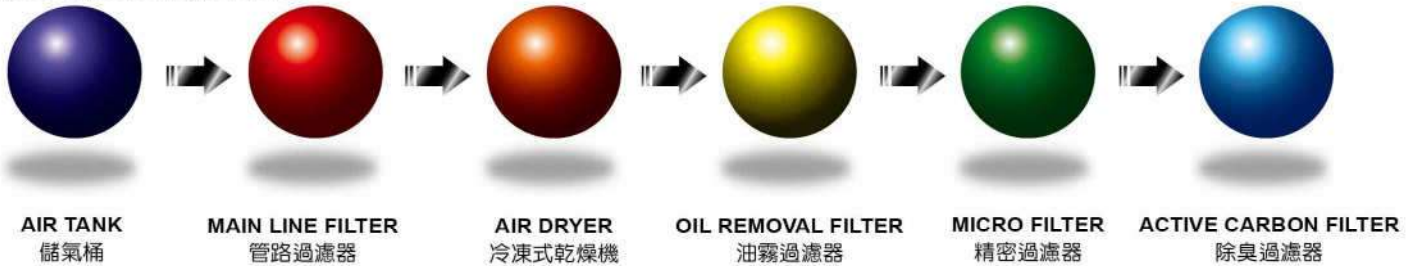

Recommended Air Filtration Combination 標準組合選配表

Model 型號 Item 項目	SVU-205	SVU-205	SWU-307	SWU-307	SWU-310	SWU-310	SWU-415	SWU-415	SVU-215	SVU-215	SVU-220	SVU-220	Model 型號				
	SVP-205	SVP-205	SWP-307	SWP-307	SWP-310	SWP-310	SWP-415	SWP-415	SVP-215	SVP-215	SVP-220	SVP-220	Size 規格	SDE-4E	SDE-8E	SDE-11E	SDE-15E
Main Line Filter 管路過濾器	---	---	---	---	---	---	ARF 15A	ARF 15A	ARF 15A	ARF 15A	ARF 15A	ARF 15A	Flow Rate(m ³ /min) 處理量	0.6	1.2	1.6	2.4
Air Dryer 冷凍式乾燥機	SDE-4E	SDE-4E	SDE-8E	SDE-8E	SDE-8E	SDE-8E	SDE-11E	SDE-11E	SDE-11E	SDE-11E	SDE-15E	SDE-15E	Dew Point 出口露點	3~15°C			
Oil Removal Filter 油霧過濾器	ARB 04A	ARB 04A	ARB 08A	ARB 08A	ARB 08A	ARB 08A	ARB 15A	ARB 15A	ARB 15A	ARB 15A	ARB 15A	ARB 15A	Inlet Temp 入口溫度	Max.80°C			
Micro Filter 精密過濾器	ARA 04A	ARA 04A	ARA 08A	ARA 08A	ARA 08A	ARA 08A	ARA 15A	ARA 15A	ARA 15A	ARA 15A	ARA 15A	ARA 15A	Ambient Temp 環境溫度	2~43°C			
													W.P.(bar) 工作壓力	2~10			
													In/Out 管徑	1/2"φ	3/4"φ	1"φ	1"φ
													Power 電源	1	1	1	1
													Type of Refrigerant 冷媒型式	R-134A	R-134A	R-407C	R-407C
													L(mm) 長	254	254	244	254
													Size W(mm) 尺寸 寬	722	722	797	797
													H(mm) 高	515	515	626	626
													Weight(kgs) 重量(kgs)	34	34	40	42
													Applicable Ranges(hp) 適用馬力(hp)	5	5~10	10~15	10~20

※Standard products supplied with 220V, and refer to us for the different voltage or higher capacity and urgent delivery.
 ※Keep on searching for excellence, we reserve the right to alter specifications without prior notice.
 ※標準電壓220V，異電壓部份與處理量較大之規範或交期請洽本公司。
 ※本公司不斷研究改進，規格如有變更，恕不另行通知。

1/4HP~20HP

Safety 耐久使用
Reliable 保養簡單



東正[®] 鐵工廠股份有限公司

TONG CHENG IRON WORKS CO., LTD.

No. 16, Sec. 2, Ta Chin Street, South Dist., Taichung 402026, Taiwan

總公司

402026 台中市南區大慶街二段16號

☎ 04 2261 2135 ☎ 04 2262 8246/04 2261 5465

🌐 www.swan-aircompressor.com

台北營業所

248018 新北市五股區五權五路43號

☎ 02 2299 1285 ☎ 02 2298 2296

台南營業所

710005 台南市永康區中正南路635號

☎ 06 253 9848 ☎ 06 253 9849



選用大豆油墨，守護地球
永續，實現美好未來。
Opt for soy ink, protect the Earth.
Sustainability, secure a brighter future.

N TYPE Series Air Cooled Piston Compressors 系列空氣壓縮機

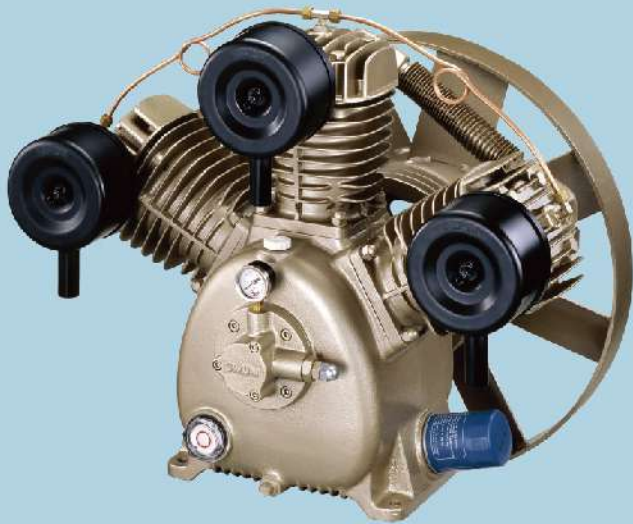

**Innovation, Automatic Control,
Easy Maintenance**

創新、自動控制與簡易維修



Special Features of Swan's N TYPE Compressors

N TYPE 獨家專利與強制式潤滑系統特點

Full combination of professional and unique technical design to lubricate all running parts inside the pump with enforced clean oil.

- Special oil carried inside the crankshaft to ensure sufficient and clean lubrication
- Built-in enforced lubricating system to guarantee full lubrication without failure.
- Long-last oil filter and oil capillary pipes to ensure the supply of clean oil.

專業與技術的極致，潔淨強制潤滑機構

- 特殊貯油式曲軸設計，即時得到充分的潔淨潤滑。
- 內藏型強制潤滑系統，簡潔確實，確保充分潤滑的有效性。
- 長效性的潤滑油過濾器與曲軸的導油管設計，確保潤滑油的潔淨。



SVU-205N

Well Spread Oil Film

強均勻潔淨的油膜

Oil Pressure Gauge

潤滑油壓力錶

Provide Immediate Lubrication

With lubricant being always kept and pumped throughout the whole lubricating system.

即時提供潤滑油

預藏型曲軸設計，儲存潤滑油。

Oil Pump

Greatly reducing oil consumption by supplying appropriate lubricant.

潤滑油幫浦

提供適量適壓之潤滑油，減少潤滑油消耗量。

High Efficient Valve Assy

高效率進排氣閥組

Precise Oil Pressure Switch

Oil alert — avoid any possibility of the compressor being blocked due to failure in lubricating.

精確的失油開關

失油開關保護，免束心之慮。

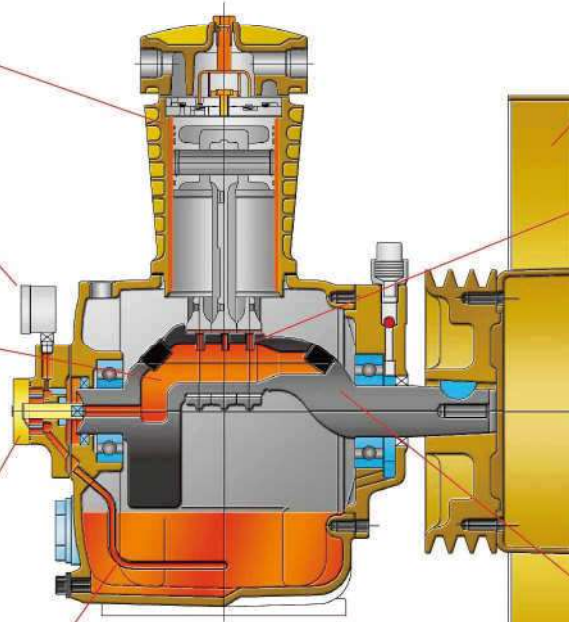

Simple And Concise Appearance

With built-in lubricating mechanism.

造型簡潔

內藏型潤滑機構，外型簡潔美觀。

Powerful Cooling Fan

強力散熱風扇

Oil Capillary Pipe

To provide clean lubricants. Equipped with oil filter and guide-piping to extend the service life of running parts.

導油管設計

提供潔淨潤滑油，增設過濾器與導油管，防止污物磨損機件。

Enforced-lubrication Crankshaft

強制潤滑型曲軸

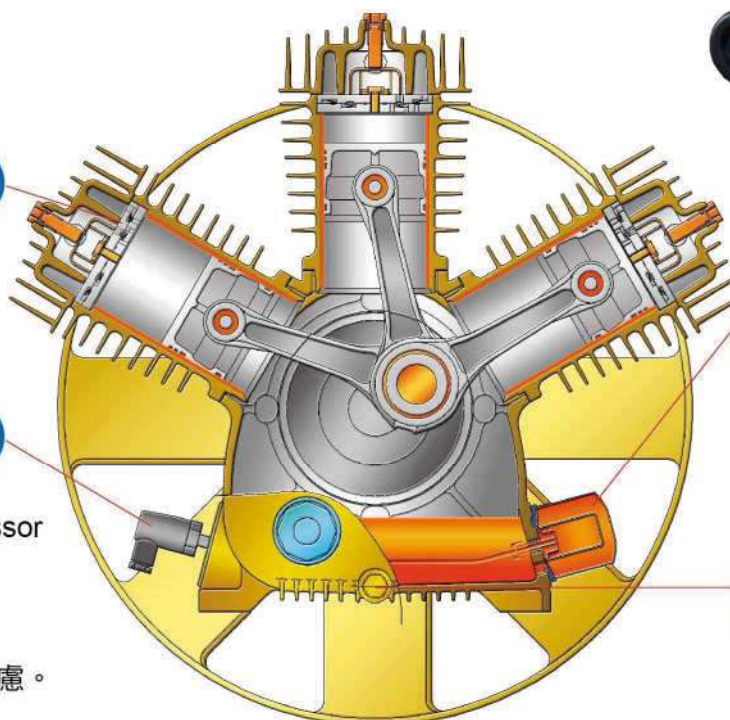

SWU-310N

Long-lasting Oil Filter

Ensure clean lubricating oil by equipping with oil filter.

長效性潤滑油過濾系統

設有過濾裝置，提供潔淨潤滑油。

Crankcase With Ample Oil reservoir Design

曲軸箱具有大型儲油槽設計。

Unique Components and Mechanism

獨特零組件與機械設計



Product quality guaranteed through the application of modern technology such as CAD-CAM software, that are widely used in all areas from product development, modeling and design, to the manufacturing process. 以CAD-CAM進行分析、模擬、設計、製造、品質的發展從設計開始。

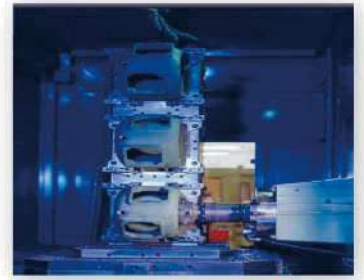

Highly efficient and durable valve assemblies are produced through the use of special heat treatments and high precision grinding processes.

經熱處理及精密研磨的進排氣閥組，注意每環節確保效率與壽命。



SWU-415N



High quality and consistent components are manufactured through machining centers which typically are capable of completing a finished surface in a single set-up. 以大型自動加工中心機進行精密加工，一次夾持完成各加工面，確保精度一致性。



All compressor surfaces and air tanks are prepared by initially shot blasting, followed by the application of powder coating to ensure bright, durable and environmentally friendly surface protection.

鋼珠噴砂處理，自動粉體塗裝；注重環保並確保外觀晶亮耐久。

Compressor Pumps

壓縮機機體

SWAN is dedicated to providing a full products line and to satisfy diverse customers' needs.

“堅持品質、不斷創新、永續服務”

是SWAN對客戶支持的回報，也是對客戶不變的承諾！



HWU-205N



HWU-307N
HWU-310N



HWU-415N

N Series

N系列 氣冷移動式

SWAN air compressors has been devoting to the development, production and rigorous quality control of all types of air compressors since its establishment in 1956. SWAN air compressors are used in a wide range of industries and get well-known reputation of high quality, reliability and durability.

1956年成立以來，SWAN以豐富的經驗、精進的技術、持續的研究，生產好品質、高可靠、長耐用的空氣壓縮機，獲得客戶的滿意與支持，並依客戶需求提供ODM/OEM特製產品。



SVU-205N



SWU-310N



HVU-205N



HWU-415N

Specs. Model 規格 型式	Motor (kw/hp) 馬達		Working Pressure (kg/cm ² .g) 使用壓力	Speed (r.p.m) 轉速		F.A.D. (l/min) 實際排氣量		Tank Capacity (liter) 儲氣桶容量	Compressor Pumps Physical Dimensions 機體實體尺寸		Compressor Units Physical Dimensions 整台實體尺寸	
				50HZ	60HZ	50HZ	60HZ		LxWxH(mm)	重量(kg)	LxWxH(mm)	重量(kg)
SVU-205N	3.7	5	8	516	620	450	545	155	560x400x450	70	1400x520x980	182
SWU-307N	5.5	7.5		706	850	723	872	240	650x460x550	93	1470x650x1150	243
SWU-310N	7.5	10		706	850	955	1151	300	700x460x560	95	1835x650x1200	263
SWU-415N	11	15		706	850	1229	1480	300	700x520x550	118	1835x650x1200	290
HVU-205N	3.7	5	16	750	900	338	406	237	560x400x450	70	1470x650x1150	239
HWU-307N	5.5	7.5		706	850	503	606	237	650x460x550	93	1470x650x1150	273
HWU-310N	7.5	10		706	850	652	786	237	700x460x550	95	1470x650x1150	275
HWU-415N	11	15	12	706	850	929	1120	300	700x520x550	118	1835x650x1200	365
HWU-307NH	5.5	7.5	30	560	700	277	346	310	700x450x560	94	1850x650x1160	273
HWU-310NH	7.5	10		560	700	371	464	310	700x450x560	95	1850x650x1160	275

※ Keep on developing for excellence, we reserve the right to alter specifications without prior notice.
 ※ Other special air discharge quantity, pressure and drive type are available upon request.

※ 本公司不斷研究改進，規格如有變更，恕不另行通知。
 ※ 規格外之壓力、排氣量、空壓設備，詳細資料歡迎與本公司洽詢。

Smart Controller

智慧型面板



復歸鍵 停止鍵 啟動鍵

- Power Indicator** 電源指示燈
- Stop Indicator** 停止指示燈
- Start Indicator** 運轉指示燈
- Stand-by Indicator** 備機指示燈
- Overload Indicator**
- O.L** 電流過負載指示燈
- Low oil Pressure Indicator**
- A.1** 失油保護指示燈
- Remote-control Indicator**
- R/L** 遠端操作指示燈

- The distinctive and high efficient design enable to eliminate wearing damages to all mechanical parts during ON/OFF and loading / unloading operations. 特殊的設計，在空車啟動與空車停機時降低磨擦阻力對機械的傷害。
- The user friendly control system can monitor exactly the running conditions of the remote compressors. 本機、遠端彈性化操控，選擇更人性化。
- Intelligent control system is able to self-adjust to execute automatic or semi-automatic control mode. 智慧型自動控制，可自動調節為全自動或半自動操作模式。
- Multiple protective system and intimate design to completely meet customers' requirements. 貼心設計，多重保護控制系統功能。
- Simple and visible indicator lights. 操控面板指示燈顯示運轉狀態。

Compressed Air Cleaning System

空氣清淨化系統

Features

- Comprehensive range of filters to meet requirements from different industrial users.
- We supply different grade of air filtrating systems to meet various applications.

特點

- 配合不同工業用戶需求，提供各種樣式過濾器組合。
- 因應客戶不同的用途，不同的清淨化需求，提供不同等級的過濾系統。



Recommended Air Combination 標準組合選配表

Item 項目	Model 型式	SVU-205N	SWU-307N SWU-310N	SWU-415N
Main Line Filter 管路過濾器		---	---	ARF 15A
Air Dryer 冷凍式乾燥機		SDE-4E	SDE-8E	SDE-11E
Oil Removal Filter 油霧過濾器		ARB 04A	ARB 08A	ARB 15A
Micro Filter 精密過濾器		ARA 04A	ARA 08A	ARA 15A

Specs. 規格	Model 型式	SDE-4E	SDE-8E	SDE-11E
Flow Rate(m ³ /min) 處理量		0.6	1.2	1.6
Dew Point 出口露點		3~15°C		
Inlet Temp 入口溫度		Max.80°C		
Ambient Temp 環境溫度		2~43°C		
W.P.(bar) 工作壓力		2~10		
In/Out 管徑		1/2"∅	3/4"∅	1"∅
Power 電源		1	1	1
Type of Refrigerant 冷媒型式		R-134A	R-134A	R-407C
Size 尺寸	L(mm) 長	254	254	244
	W(mm) 寬	722	722	797
	H(mm) 高	515	515	626
Weight(kg) 重量		34	34	40
Applicable Ranges(hp) 適用馬力		5	5~10	10~15



※Standard products supplied with 220V, and refer to us for the different voltage or higher capacity and urgent delivery.

※Keep on searching for excellence, we reserve the right to alter specifications without prior notice.

※標準電壓220V，異電壓部份與處理量較大之規範或交期請洽本公司。

※本公司不斷研究改進，規格如有變更，恕不另行通知。

5~15HP

Excellent Efficiency Superior Performance

運轉高效率
實用高性能



東正[®] 鐵工廠股份有限公司

TONG CHENG IRON WORKS CO., LTD.

No. 16, Sec. 2, Ta Chin Street, South Dist., Taichung 402026, Taiwan

總公司

402026 台中市南區大慶街二段16號

☎ +886 4 2261 2135 ☎ +886 4 2262 8246/+886 4 2261 5465

🌐 www.swan-aircompressor.com

台北營業所

248018 新北市五股區五權五路43號

☎ +886 2 2299 1285 ☎ +886 2 2298 2296

台南營業所

710005 台南市永康區中正南路635號

☎ +886 6 253 9848 ☎ +886 6 253 9849



選用大豆油墨，守護地球
永續，實現美好未來。

Opt for soy ink, protect the Earth.
Sustainability, secure a brighter future.

ENGINE TYPE AIR COMPRESSOR SERIES

1. SWAN high quality air compressor pump
2. Engine driven
3. Powder coated air tank

◆ Engine driven

Driven by diesel power, free from limitation of power source, offer superb quality of compressed air anytime and anyplace. Able to process repairs anywhere.

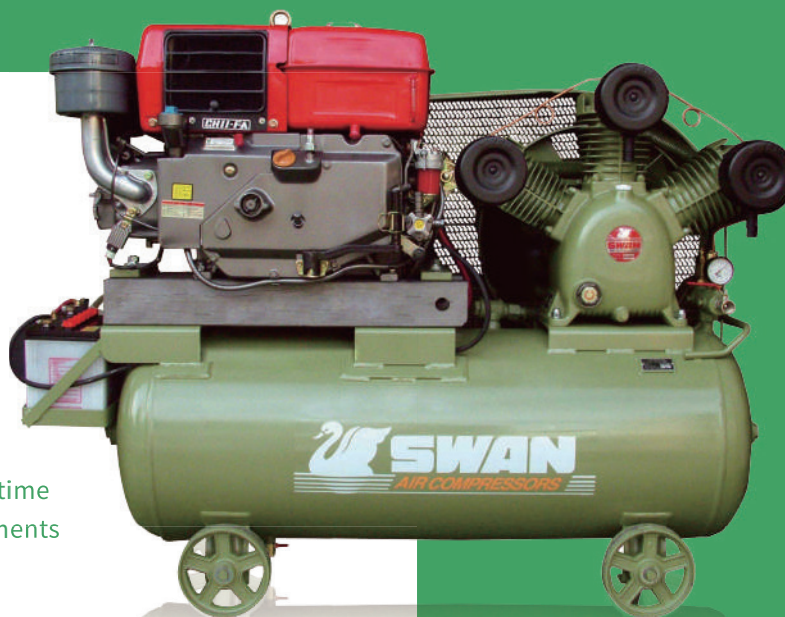

Detailed specifications

Model	Power (HP)	Power (kW)	Working Pressure (kg/cm ²)	Capacity (m ³ /min)	Tank Capacity (liter)	Dimension (mm) (L*W*H)	Weight (kg)
SVU-201E(gas)	5.5	4.13	8	0.14	85	1100x440x780	58
SVU-202E(gas)	5.5	4.13	8	0.225	85	1100x440x780	62
SVU-203E(gas)	6	4.5	8	0.355	240	1620x510x1165	190
SVU-203E(diesel)	6	4.5	8	0.355	240	1620x510x1165	190
SVU-205E(gas)	8	6	8	0.545	240	1525x550x1170	220
SVU-205E(diesel)	10.5	7.88	8	0.545	240	1525x550x1200	230
SWU-307E(diesel)	13	9.75	8	0.872	300	1835x650x1200	300
SWU-310E(diesel)	18	13.5	8	1.151	300	1835x650x1220	345
HVU-203E(gas)	5.5	4.13	16	0.270	237	1670x510x1165	240
HVU-203E(diesel)	6	4.5	16	0.270	237	1670x510x1165	240
HVU-205E(gas)	8	6	16	0.406	237	1670x550x1210	270
HVU-205E(diesel)	10.5	7.88	16	0.406	237	1560x550x1250	275
HWU-307E(diesel)	13	9.75	16	0.606	237	1630x640x1285	335
HWU-310E(diesel)	18	13.5	16	0.786	237	1630x640x1300	372

※ SWAN Air Compressors keep on searching for excellence, we reserve the right to alter specifications without prior notice.



東正鐵工廠股份有限公司
TONG CHENG IRON WORKS CO., LTD.
No. 16, Sec. 2, Ta Chin Street, South Dist.,
Taichung 402026, Taiwan

MAIL swantc@swanair.com.tw
TEL +886-4-2261-2135
FAX +886-4-2262-8246

